

# Fit Line FL41A

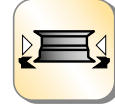

21''



\* HTB21

\*helper a richiesta - helper optional - Helper auf Anfrage

EN

Automatic tyre changer for cars, lightweight transport vehicles and motor vehicles

**HELPER HTB21 optional**

(code 8-11900261)

Universal multifunctional device for facilitating tyre mounting and demounting

IT

Smontagomme automatico per autovetture, trasporto leggero, motoveicoli e scooter

**HELPER HTB21 a richiesta**

(code 8-11900261)

Dispositivo multifunzionale universale per agevolare montaggio e smontaggio pneumatico

DE

Automatische Reifenmontiermaschine für PKWs, Kleintransporter, Motorräder und Motorroller

**HELPER HTB21 auf Anfrage**

(Artikelnummer 8-11900261)

Universelle Mehrzweckvorrichtung zur Erleichterung der Reifenmontage- und demontage



EN → Recommended accessories IT → Accessori consigliati DE → Empfohlenes Zubehör



EN → **CT-S-0200000** - Plastic bead pressing clamp • **CT-S-0110000** - Demount head quick change tool • **CT-S-0310000** - Plastic demount head assy (for tilt back model use) • **C-21-8000100** - Motorcycle demount head • **C-M-0200000A** - Motorcycle adaptor (hand roller style), for STANDARD jaw system use • **CT-S-0600000** - Wheel rotation support WRSB • **8-11900271** - Lever and shoe plastic protection kit • **8-11900270** - Plastic protection kit • **8-11120075** - Wheel lifter FWL 65  
 ••For further information, consult the complete accessories catalogue

IT → **CT-S-0200000** - Pinza premitallone in plastica • **CT-S-0110000** - Attrezzo per cambio rapido testina di smontaggio • **CT-S-0310000** - Gruppo testina di smontaggio in plastica (per modelli a ribaltamento) • **C-21-8000100** - Testina di smontaggio motocicletta • **C-M-0200000A** - Adattatore motocicletta (stile rullo manuale), per uso con sistema a griffe STANDARD • **CT-S-0600000** - Supporto rotazione ruota WRSB • **8-11900271** - Kit protezione in plastica leva e paletta • **8-11900270** - Kit protezioni in plastica • **8-11120075** - Sollevatore ruota FWL 65. ••Per maggiori informazioni consultare il catalogo accessori completo.

DE → **CT-S-0200000** - PVC wulsthalteklemme • **CT-S-0110000** - Schnellverschluss Demontagekopf • **CT-S-0310000** - Schnellverschluss Kunststoff-Montagekopf (nur für Modelle mit kippbarer Montagesäule) • **C-21-8000100** - Motorrad-Montagekopf • **C-M-0200000A** - Motorrad Anpasser (Handrolle) für STANDARD Klauensystem Verwendung • **CT-S-0600000** - Raddrehhalter WRSB • **8-11900271** - Kit Schutzelemente aus Kunststoff für Hebel und Schaufel • **8-11900270** - Kit Schutzelemente aus Kunststoff • **8-11120075** - Radheber für Räder FWL 65 ••Für weitere Informationen schlagen Sie bitte im Gesamtkatalog des Zubehörs nach.

EN → Dimensions

IT → Dimensioni

DE → Abmessungen

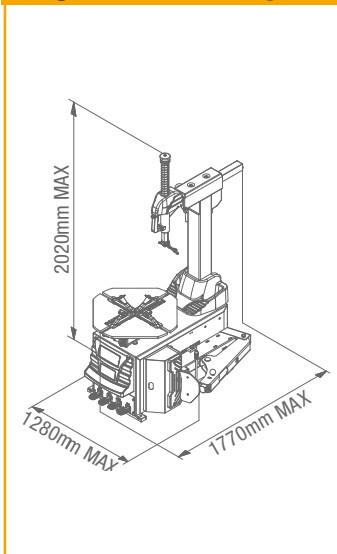

EN → Technical Data IT → Dati Tecnici DE → Technische Daten

Outside Clamp	Presca esterna	Spannbereich außen	10" - 21"
Inside Clamp	Presca interna	Spannbereich innen	12" - 24"
Max. wheel diameter	Diametro max. ruota	Maximaler Raddurchmesser	1040 mm
Tire Width	Larghezza pneumatico	Reifenbreite	3" - 12"
Bead-breaker opening	Apertura stallonatore	Abdrückvorrichtung Öffnung	320 mm
Bead-breaking power	Potenza stallonatura	Abdrückkraft	15000 N
Working air Pressure	Pressione di esercizio aria	Arbeitsluftdruck	8 - 10 bar
Motor Power (pedal control two speed motor)	Potenza motore (motore a due velocità con comando a pedale)	Motorleistung (Pedalsteuerung Motor mit zwei Drehgeschwindigkeiten)	0,85 kW - 1.1 kW
Turntable rotation speed	Velocità rotazione mandrino	Spannfutter Rotationsgeschwindigkeit	7 rpm - 2V 6.5 -13 rpm
Noise level (running)	Rumorosità durante il funzionamento	Laufender Geräuschpegel	<70 dB
Machine nett weight	Peso netto macchina	Nettogewicht Maschine	246 kg
Machine gross weight	Peso lordo macchina	Bruttogewicht Maschine	285 kg
Crate dimensions (WxLxH)	Dimensione max imballo (LxPxH)	Max. Abmessungen Verpackung (LxBxH)	1130x910x1010 mm
Machines in 40' container	Per contenitore da 40'	Für 40' Behälter	36 pcs

The manufacturer reserves the right to modify the features of its products at any time. Fotografie, caratteristiche ed i dati tecnici non sono vincolanti, possono subire modifiche senza preavviso. Die Fotografien, die angegebenen Eigenschaften und die technischen Daten sind nicht verbindlich und können ohne Vorankündigung geändert werden.